

Telling Architectural Ltd

Primrose Avenue
Fordhouses
Wolverhampton
West Midlands WV10 8AW

Tel: 01902 789777 Fax: 01902 398777

e-mail: info@telling.co.uk

website: www.telling.co.uk



**Agrément Certificate
No 08/4516**

PRODUCT SHEET 1 — ARGETON TERRACOTTA RAINSCREEN CLADDING SYSTEM

PRODUCT SCOPE AND SUMMARY OF CERTIFICATE

This Certificate relates to the ArGeTon Terracotta Rainscreen Cladding System for use as a decorative/protective façade over the external walls of buildings.

AGRÉMENT CERTIFICATION INCLUDES:

- factors relating to compliance with Building Regulations where applicable
- factors relating to additional non-regulatory information where applicable
- independently verified technical specification
- assessment criteria and technical investigations
- design considerations
- installation guidance
- regular surveillance of production
- formal three-yearly review.



KEY FACTORS ASSESSED

Practicability of installation — the system is suitable for installation by cladding contractors providing they have undergone suitable training by the Certificate holder (see section 4).

Strength and stability — the system can be designed to resist wind loads normally encountered in the UK (see section 5).

Behaviour in relation to fire — for reaction to fire, the system may be regarded as having a Class 0 surface in relation to The Building Regulations 2000 (as amended) (England and Wales), and a 'low risk' material as defined in The Building (Scotland) Regulations 2004 (as amended) (see section 6).

Air and water penetration — the baffled vertical and horizontal joints between the tiles will minimise water entering the cavity. Any water collecting in the cavity will be removed by drainage and ventilation (see section 7).

Maintenance — damaged tiles may be replaced individually without disturbing adjacent tiles (see section 8).

Durability — in normal UK conditions, the system will have a service life in excess of 35 years (see section 9).

The BBA has awarded this Agrément Certificate for the ArGeTon Terracotta Rainscreen Cladding System to Telling Architectural Ltd as fit for its intended use provided it is installed, used and maintained as set out in this Agrément Certificate.

On behalf of the British Board of Agrément

Greg Cooper: Chief Executive

Date of First issue: 21 January 2008

The BBA is a UKAS accredited certification body — Number 113. The schedule of the current scope of accreditation for product certification is available in pdf format via the UKAS link on the BBA website at www.bbacerts.co.uk

Readers are advised to check the validity and latest issue number of this Agrément Certificate by either referring to the BBA website or contacting the BBA direct.

British Board of Agrément
Bucknalls Lane
Garston, Watford
Herts WD25 9BA

©2008

tel: 01923 665300
fax: 01923 665301
e-mail: mail@bba.star.co.uk
website: www.bbacerts.co.uk

Regulations

In the opinion of the BBA, the ArGeTon Terracotta Rainscreen Cladding System, if used in accordance with the provisions of this Certificate, will meet, or contribute to meeting, the relevant requirements of the following Building Regulations:



The Building Regulations 2000 (as amended) (England and Wales)

Requirement:	A1	Loading
Comment:		The system is acceptable for use as set out in sections 3.2 and 5.1 to 5.8 of this Certificate.
Requirement:	B4(1)	External fire spread
Comment:		The system is judged to meet the Class 0 requirements. See sections 6.1 to 6.4 of this Certificate.
Requirement:	C2(b)(c)	Resistance to moisture
Comment:		The system will meet the stated requirements. See sections 7.1 to 7.5 of this Certificate.
Requirement:	Regulation 7	Materials and workmanship
Comment:		The system is acceptable. See section 9.1 of this Certificate.



The Building (Scotland) Regulations 2004 (as amended)

Regulation:	8	Fitness and durability of materials and workmanship
Regulation:	8(1)	Fitness and durability of materials and workmanship
Comment:		The system can contribute to a construction satisfying this Regulation. See section 9.1 and the <i>Installation</i> part of this Certificate.
Regulation:	9	Building standards – construction
Standard:	1.1(a)(b)	Structure
Comment:		The system is acceptable, with reference to clause 1.1.1 ⁽¹⁾⁽²⁾ . See sections 3.2 and 5.1 to 5.8 of this Certificate.
Standard:	2.4	Cavities
Comment:		The system, when used in conjunction with fire-resistant materials, can meet this Standard, with reference to clauses 2.4.1 ⁽¹⁾⁽²⁾ , 2.4.2 ⁽¹⁾⁽²⁾ and 2.4.9 ⁽¹⁾⁽²⁾ . See section 6.4 of this Certificate.
Standard:	2.6	Spread to neighbouring buildings
Comment:		The system can contribute to satisfying this Standard, with reference to clauses 2.6.4 ⁽¹⁾⁽²⁾ , 2.6.5 ⁽¹⁾ and 2.6.6 ⁽²⁾ . See sections 6.1 to 6.4 of this Certificate.
Standard:	2.7	Spread on external walls
Comment:		The system can contribute to satisfying this Standard, with reference to clause 2.7.1 ⁽¹⁾⁽²⁾ . See sections 6.1 to 6.3 of this Certificate.
Standard:	3.10	Precipitation
Comment:		The system will contribute to meeting this Standard, with reference to clauses 3.10.1 ⁽¹⁾⁽²⁾ to 3.10.3 ⁽¹⁾⁽²⁾ , 3.10.5 ⁽¹⁾⁽²⁾ and 3.10.6 ⁽¹⁾⁽²⁾ . See sections 7.1 to 7.5 of this Certificate. (1) Technical Handbook (Domestic). (2) Technical Handbook (Non-Domestic).



The Building Regulations (Northern Ireland) 2000 (as amended)

Regulation:	B2	Fitness of materials and workmanship
Comment:		The system is acceptable. See section 9.1 of this Certificate.
Regulation:	C4	Resistance to ground moisture and weather
Comment:		The system will contribute to meeting this Regulation. See sections 7.1 to 7.5 of this Certificate.
Regulation:	D1	Stability
Comment:		The system is acceptable as set out in sections 3.2 and 5.1 to 5.8 of this Certificate.
Regulation:	E5	External fire spread
Comment:		The system is judged to meet the Class 0 requirements. See sections 6.1 to 6.4 of this Certificate.

Construction (Design and Management) Regulations 2007

Construction (Design and Management) Regulations (Northern Ireland) 1995 (as amended)

Information in this Certificate may assist the client, CDM co-ordinator or planning supervisor, designer and contractors to address their obligations under these Regulations.

See sections: 1 *Description* (1.4) and 2 *Delivery, storage and site handling* (2.5 and 2.6).

Non-regulatory Information

NHBC Standards 2007

NHBC accepts the use of the ArGeTon Terracotta Rainscreen Cladding System, when installed and used in accordance with this Certificate, as meeting the requirements of the *NHBC Standards, Chapter 6.9 Curtain walling and cladding, Clause D8*.

Zurich Building Guarantee Technical Manual 2007

In the opinion of the BBA, the use of the ArGeTon Terracotta Rainscreen Cladding System in relation to this Certificate is not subject to the requirements of this Technical Manual.

General

This Certificate relates to the ArGeTon Terracotta Rainscreen Cladding System, comprising terracotta tiles fixed to aluminium support rails to provide a decorative/protective façade over the external walls of buildings.

The sub-frame, miscellaneous construction details and attachment to the supporting walls are outside the scope of this Certificate, as they are selected according to the structure as well as the offset required to accommodate the specified insulation in the cavity.

It is important for the designers, planners, contractors and/or installers to ensure that the installation of the cladding is in accordance with the Certificate holder's instructions and the information given in this Certificate.

Technical Specification

1 Description

1.1 The ArGeTon Terracotta Rainscreen Cladding System comprises ceramic tiles which are fixed onto vertical or horizontal aluminium support rails via purpose-made metal clamps. The clamps, clips, aluminium support system and components, are outside the scope of this Certificate as are other miscellaneous construction details (see Figure 1).

Figure 1 General arrangement of support systems

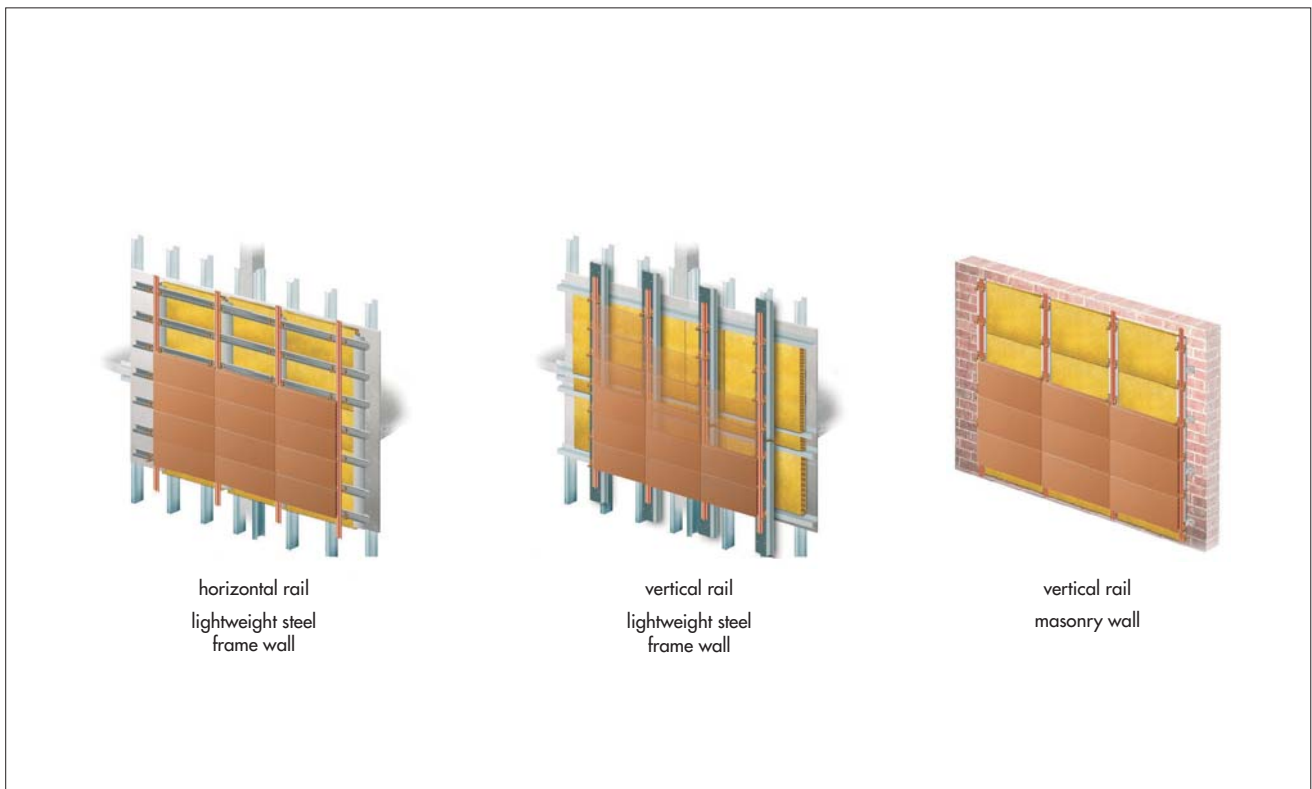

1.2 The tiles are of one basic design in a range of sizes as follows (see Figure 2):

- height — 150 mm to 300 mm in 12.5 mm increments
- length — 150 mm to 1250 mm to suit individual project
- nominal thickness — 30 mm.

Figure 2 Tile modules (dimensions in mm)

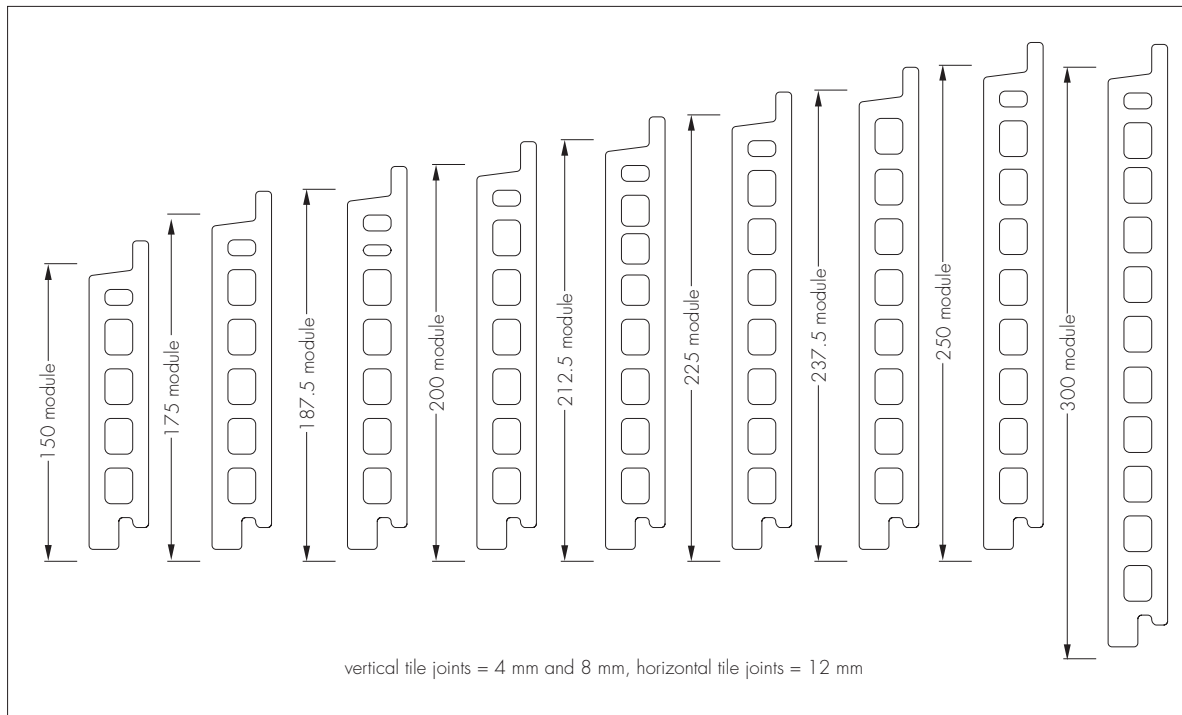

1.3 The tiles are manufactured in Germany, from natural clay, and are available in standard smooth, glazed, engobe, riven, brushed or wire dragged finishes in 13 natural mineral colours.

1.4 The tiles have a maximum dry mass of 50 kgm^{-2} and the system has a maximum total installed mass of 55 kgm^{-2} .

1.5 Quality control of the tiles is achieved through regular surveillance of production carried out by an inspection body on behalf of the BBA.

1.6 All ancillary components designed to support the tiles are of aluminium grade 6063 T6 and are bought-in to agreed specifications (see Figure 3). Slotted holes are provided in the rail to sub-frame attachment brackets to allow correct alignment.

Figure 3 Ancillary components – all at aluminium grade 6063 T6 (dimensions in mm)

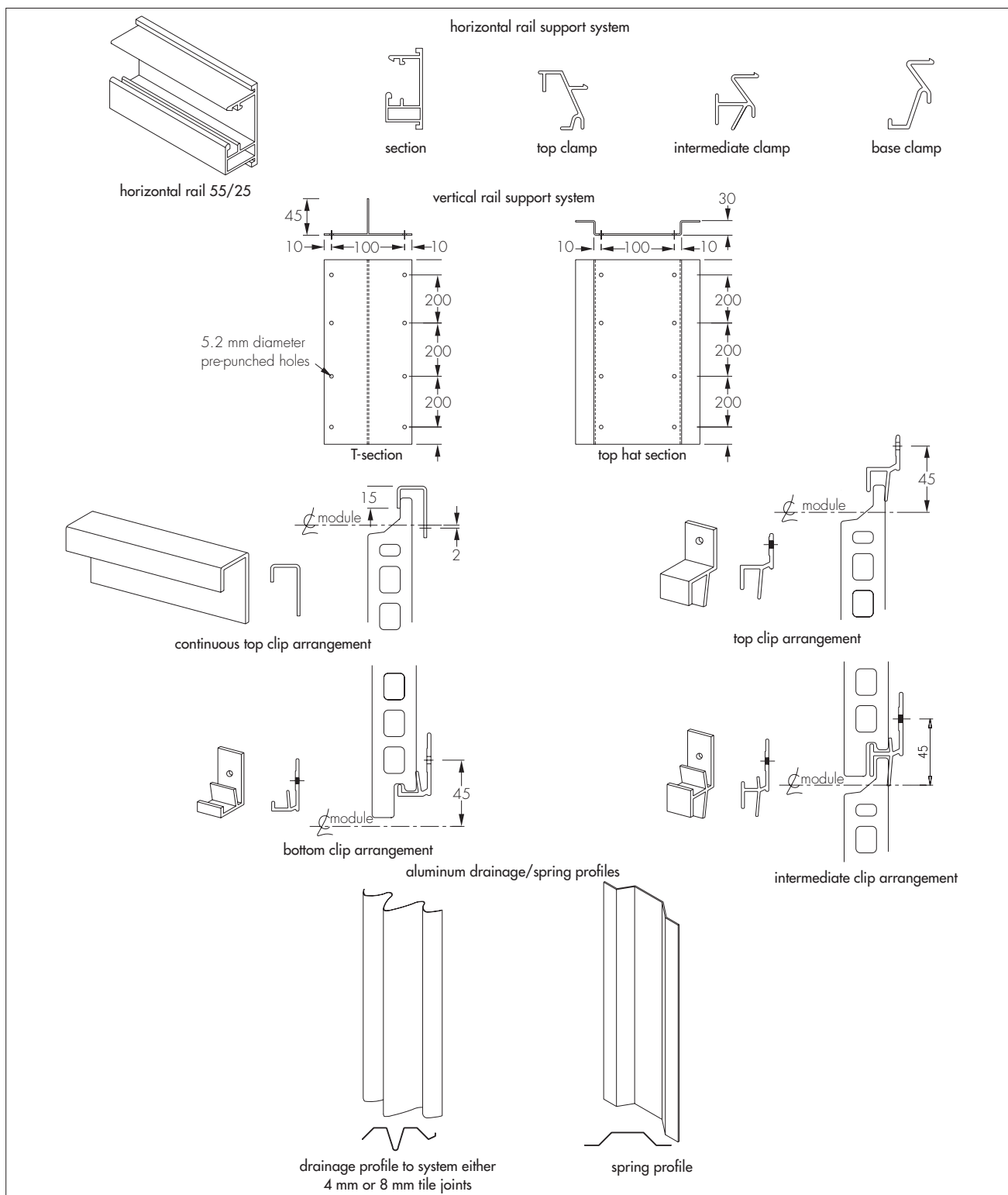

2 Delivery, storage and site handling

2.1 The tiles are delivered to site in packs of five, with each pack separated by a piece of cardboard and stacked, no more than five tile-widths high, onto pallets and shrink wrapped. The pallets bear product details such as type, size, quantity, identification code, manufacturing references and colour.

2.2 To prevent damage to the tiles, the pallets should not be stacked on top of each other.

2.3 The aluminium support rails are delivered to site banded onto a wooden pallet with ancillary items in separate cardboard boxes.

2.4 Packs of rails should be stacked horizontally on sufficient bearers to prevent distortion, to a maximum height of 1 m. Other components should be safely stored until ready for use.

2.5 The tiles should be handled with care to avoid damage or breakage. Care is required when handling long lengths of rail, particularly at height.

2.6 Protective clothing should be worn as required and all Health and Safety regulations should be observed.

Assessment and Technical Investigations

The following is a summary of the assessment and technical investigations carried out on the ArGeTon Terracotta Rainscreen Cladding System.

Design Considerations

3 Use

3.1 The ArGeTon Terracotta Rainscreen Cladding System must be provided with back ventilation and drainage. The cavity behind the cladding should be as wide as possible, with a minimum ventilation area of 100 cm² per metre run of cladding. The ventilation openings, where wider than 10 mm, should be suitably protected, or baffled, to prevent the ingress of birds, vermin and rain.



3.2 The wall and the sub-frame to which the cladding is fixed should be structurally sound and constructed in accordance with the requirements of the relevant Building Regulations and national standards.

3.3 The wall to which the cladding is fixed should be watertight and resistant to the transmission of heat and sound.

3.4 As the rainscreen is open jointed, the insulation behind the cladding needs to be suitably fixed to the supporting wall, and protected, to resist the forces of wind suction. Insulation should be of a rigid type (eg boards or batts). The ventilation pathway behind the cladding must not be allowed to become blocked nor the insulation dislodged where it may be vulnerable to wetting.

3.5 To allow for thermal expansion, a gap of 2 mm gap per metre length of aluminium support rail between adjacent rails should be provided.

3.6 All design aspects of the installation should be checked by a suitably qualified engineer or other appropriately qualified person. For advice on specific construction details, eg flue pipe penetrations, the Certificate holder should be consulted.

4 Practicability of installation

The system is suitable for installation by cladding contractors provided they have undergone suitable training by the Certificate holder.

5 Strength and stability

Wind loading



5.1 The 600 mm by 300 mm tile format, when tested for wind loading, achieved a maximum pressure (positive or negative) of 2.4 kPa for serviceability and 3.6 kPa for safety.

5.2 Provided the distance between clamps (or clips) along the tile length does not exceed 600 mm and that between clamps (or clips) across the tile width does not exceed 300 mm, all the tile formats covered by this Certificate should be capable of resisting wind pressures likely to be encountered in the UK.

5.3 Fixing of the support rails to the sub-frame should ensure adequate tensile pull-out and corrosion resistance (not covered by this Certificate).

5.4 When calculating wind loads, higher pressure coefficients applicable to corners of the building should be used.

5.5 Design of the cladding support structure should be such as to limit the mid-span deflections to L/200 and cantilever deflections to L/150.

5.6 A suitably qualified engineer must check the design and installation of the cladding system.

5.7 As the rainscreen is open-jointed, the supporting wall must be able to take the full wind, as well as any racking, loads on its own. No contribution from the cladding may be assumed in this regard.

5.8 Wind loads should be calculated in accordance with BS EN 1991-1-4 : 2005 and BS 6399-2 : 1997.

Impact

5.9 The 600 mm by 300 mm tile format, when tested for impact, achieved a resistance of 500 Nm for soft body and 10 Nm for hard body impact. The format may, therefore, be used in locations accessible to those with little incentive to exercise care and where there is likelihood of accident or of misuse, such as defined in Table 2 of BS 8200 : 1985, categories B to F.

6 Behaviour in relation to fire



6.1 For reaction to fire, the ceramic tiles, aluminium support rails and their fixings are non-combustible and may therefore be regarded as having a Class 0 surface in relation to the Approved Document B of The Building Regulations 2000 (as amended) (England and Wales) and Technical Booklet E of The Building Regulations

(Northern Ireland) 2000 (as amended) and 'low risk' material as defined in Annex 2C⁽¹⁾ and Annex 2E⁽²⁾ of The Building (Scotland) Regulations 2004 (as amended).

(1) Technical Handbook (Domestic).

(2) Technical Handbook (Non-Domestic).

6.2 For resistance to fire, the performance of a wall incorporating the rainscreen can only be determined by tests from a suitably accredited laboratory and is not covered by this Certificate.

6.3 The incorporation of combustible material behind the cladding should be avoided wherever possible; any insulation should be non-combustible.

6.4 Cavity barriers should be incorporated behind the cladding, as required under the national Building Regulations, but should not block essential ventilation and drainage pathways.

7 Air and water penetration



7.1 The system is not watertight, but intentionally open-jointed, back ventilated and drained.

7.2 The supporting wall must be watertight and reasonably airtight.

7.3 The 4 mm and 8 mm vertical joints, coinciding with the vertical sub-frame rail, and the 12 mm baffled horizontal joint should minimise water penetration into the cavity. Any water collecting in the cavity due to rain or condensation will be removed by ventilation and drainage.

7.4 To protect the supporting wall or insulation from wind-driven rain, a vapour permeable membrane, conforming to BS 4016 : 1997, should be applied (not covered by this Certificate).

7.5 The air space between the back of the tiles and supporting wall or insulation should be as wide as possible and should allow for conventional building tolerances. Guidance on recommended cavity widths is given in NHBC Standards 2007, Chapter 6.9.

8 Maintenance

8.1 Cleaning at regular intervals should be undertaken. For normal soiling, the surface may be cleaned using hot water/household detergent mixture, applied with a suitable cleaning pad or sponge. For more difficult chemical soiling, the manufacturer's specialist advice must be sought.

8.2 Annual maintenance inspections should be carried out to ensure that all drainage channels are in good order and that the tiles, flashings and seals are in place and are secure.

8.3 Damaged tiles should be replaced as soon as practicable following the manufacturer's instructions and observing all necessary health and safety regulations. The specially designed metal clips allow individual tiles to be replaced without disturbing adjacent tiles (see Figure 1).

9 Durability



9.1 The tiles will have a service life in excess of 35 years when used in normal exposure conditions in the United Kingdom.

9.2 After natural weathering, a slight change in colour shade may occur, particularly on the dark-coloured material. However, this process is not likely to be progressive.

9.3 The aluminium sub-frame components will have a service life at least commensurate with that of the tiles they are supporting.

Installation

10 General

10.1 The ArGeTon Rainscreen Cladding System must be installed and fixed in accordance with the Certificate holder's recommendations, the requirements of this Certificate and specifications laid down by the consulting engineer.

10.2 Installers must be trained and approved by the Certificate holder who can provide technical assistance at the design stage and at the start of the installation.

10.3 Reference should be made to Figures 1 and 2 when reading the procedural details given in section 11.

10.4 If significant colour variations between batches is likely, it may be necessary to mix the tiles from different pallets so as to obtain a uniform shade over the façade.

11 Procedure

11.1 Based on the architectural and design specifications, a grid layout is first prepared. Accurate grid positioning and installation of the sub-frame is essential.

11.2 Depending on the substrate wall and the support system adopted, the aluminum tile support rails or clips should be attached to the sub-frame and correctly aligned to receive the tiles.

11.3 Permeable membrane should be applied to protect the substrate wall, or insulation, as appropriate.

11.4 The tiles are then secured to the support rails via the clamps or clips.

Technical Investigations

The following is a summary of the technical investigations carried out on the ArGeTon Terracotta Rainscreen Cladding System.

12 Investigations

12.1 Using test data from accredited facilities, an assessment was made of the system's resistance to wind loading and impact.

12.2 An assessment was made of the system's durability, behaviour in relation to fire and practicability of installation.

12.3 An assessment was made of the tile production method, associated quality control procedures, and the system's history of use.

12.4 The Certificate holder's technical literature and detail drawings were examined for any inconsistencies and general content.

Bibliography

BS 4016 : 1997 *Specification for flexible building membranes (breather type)*

BS 6399-2 : 1997 *Loading for buildings — Code of practice for wind loads*

BS 8200 : 1985 *Code of practice for design of non-loadbearing external vertical enclosures of buildings*

BS EN 1991-1-4 : 2005 *Eurocode 1 : Actions on structures — General actions — Wind actions*

13 Conditions

13.1 This Certificate:

- relates only to the product/system that is named and described on the front page
- is granted only to the company, firm or person named on the front page — no other company, firm or person may hold or claim any entitlement to this Certificate
- is valid only within the UK
- has to be read, considered and used as a whole document — it may be misleading and will be incomplete to be selective
- is copyright of the BBA
- is subject to English law.

13.2 References in this Certificate to any Act of Parliament, Statutory Instrument, Directive or Regulation of the European Union, British, European or International Standard, Code of Practice, manufacturers' instructions or similar publication, are references to such publication in the form in which it was current at the date of this Certificate.

13.3 This Certificate will remain valid for an unlimited period provided that the product/system and the manufacture and/or fabrication including all related and relevant processes thereof:

- are maintained at or above the levels which have been assessed and found to be satisfactory by the BBA
- continue to be checked as and when deemed appropriate by the BBA under arrangements that it will determine
- are reviewed by the BBA as and when it considers appropriate.

13.4 In granting this Certificate, the BBA is not responsible for:

- the presence or absence of any patent, intellectual property or similar rights subsisting in the product/system or any other product/system
- the right of the Certificate holder to manufacture, supply, install, maintain or market the product/system
- individual installations of the product/system, including the nature, design, methods and workmanship of or related to the installation
- the actual works in which the product/system is installed, used and maintained, including the nature, design, methods and workmanship of such works.

13.5 Any information relating to the manufacture, supply, installation, use and maintenance of this product/system which is contained or referred to in this Certificate is the minimum required to be met when the product/system is manufactured, supplied, installed, used and maintained. It does not purport in any way to restate the requirements of the Health & Safety at Work etc Act 1974, or of any other statutory, common law or other duty which may exist at the date of this Certificate; nor is conformity with such information to be taken as satisfying the requirements of the 1974 Act or of any statutory, common law or other duty of care. In granting this Certificate, the BBA does not accept responsibility to any person or body for any loss or damage, including personal injury, arising as a direct or indirect result of the manufacture, supply, installation, use and maintenance of this product/system.

